

General Description

These N-Channel enhancement mode power field effect transistors are using silicon carbide technology. This advanced technology has been especially tailored to minimize on-state resistance, provide superior switching performance, and withstand high energy pulse in the avalanche and commutation mode. These devices are well suited for high efficiency fast switching applications.

BVDSS	$R_{DS(ON)(typ)}$	ID
1200V	80mΩ	30A

Features

- 1200V,30A, $R_{DS(ON)(typ)} = 80m\Omega @ V_{GS} = 18V$
- Improved dv/dt capability
- Fast switching
- Green Device Available

TO247-4L Pin Configuration

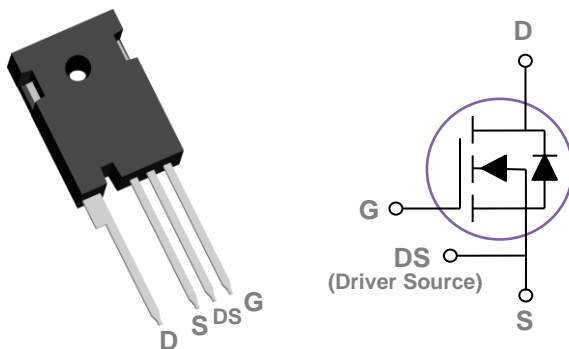

Applications

- SMPS
- Solar Inverters
- Renewable energy
- EV battery chargers

Absolute Maximum Ratings $T_c=25^\circ C$ unless otherwise noted

Symbol	Parameter	Rating	Units
V_{DS}	Drain-Source Voltage	1200	V
V_{GS}	Gate-Source Voltage	+22/-10	V
I_D	Drain Current – Continuous ($T_c=25^\circ C$)	30	A
	Drain Current – Continuous ($T_c=100^\circ C$)	19	A
I_{DM}	Drain Current – Pulsed ¹	65	A
P_D	Power Dissipation ($T_c=25^\circ C$)	176	W
	Power Dissipation – Derate above $25^\circ C$	1.18	W/ $^\circ C$
T_{STG}	Storage Temperature Range	-55 to 175	$^\circ C$
T_J	Operating Junction Temperature Range	-55 to 175	$^\circ C$

Thermal Characteristics

Symbol	Parameter	Typ.	Max.	Unit
$R_{\theta JC}$	Thermal Resistance Junction to Case	0.85	---	$^\circ C/W$

Electrical Characteristics (T_J=25 °C, unless otherwise noted)
Off Characteristics

Symbol	Parameter	Conditions	Min.	Typ.	Max.	Unit
BV _{DSS}	Drain-Source Breakdown Voltage	V _{GS} =0V , I _D =100μA	1200	---	---	V
I _{DSS}	Drain-Source Leakage Current	V _{DS} =1200V , V _{GS} =0V , T _J =25°C	---	---	10	μA
I _{GSS}	Gate-Source Leakage Current	V _{GS} =22V , V _{DS} =0V	---	---	100	nA

On Characteristics

R _{DS(ON)}	Static Drain-Source On-Resistance	V _{GS} =18V , I _D =10A	---	80	104	mΩ
R _{DS(ON)}	Static Drain-Source On-Resistance	V _{GS} =15V , I _D =10A	---	92	---	mΩ
V _{GS(th)}	Gate Threshold Voltage	V _{GS} =V _{DS} , I _D =5mA	2.0	2.6	4.0	V

Dynamic and switching Characteristics

Q _g	Total Gate Charge	V _{DS} =800V , V _{GS} =-5/18V , I _{DS} =20A	---	45	---	nC
Q _{gs}	Gate-Source Charge		---	8	---	
Q _{gd}	Gate-Drain Charge		---	14.5	---	
T _{d(on)}	Turn-On Delay Time	V _{DD} =800V , V _{GS} =-5/18V , R _G =6Ω , I _{DS} =20A	---	15	---	ns
T _r	Rise Time		---	8	---	
T _{d(off)}	Turn-Off Delay Time		---	16	---	
T _f	Fall Time		---	8	---	
C _{iss}	Input Capacitance	V _{DS} =1000V , V _{GS} =0V , F=500kHz , V _{AC} =25mV	---	915	---	pF
C _{oss}	Output Capacitance		---	57	---	
C _{rss}	Reverse Transfer Capacitance		---	3	---	
R _g	Gate resistance	V _{GS} =0V , V _{DS} =0V , F=1MHz	---	1	---	Ω

Drain-Source Diode Characteristics and Maximum Ratings

Symbol	Parameter	Conditions	Min.	Typ.	Max.	Unit
I _S	Continuous Source Current	V _G =V _D =0V , Force Current	---	---	30	A
V _{SD}	Diode Forward Voltage	V _{GS} =-5V , I _S =10A , T _J =25°C	---	4.4	---	V
t _{rr}	Reverse Recovery Time	V _R =400V , I _S =20A	---	42	---	ns
Q _{rr}	Reverse Recovery Charge	di/dt=300A/μs , T _J =25°C	---	65	---	nC

Note :

1. Repetitive Rating : Pulsed width limited by maximum junction temperature.
2. The data tested by pulsed , pulse width ≤ 300μs , duty cycle ≤ 2%.

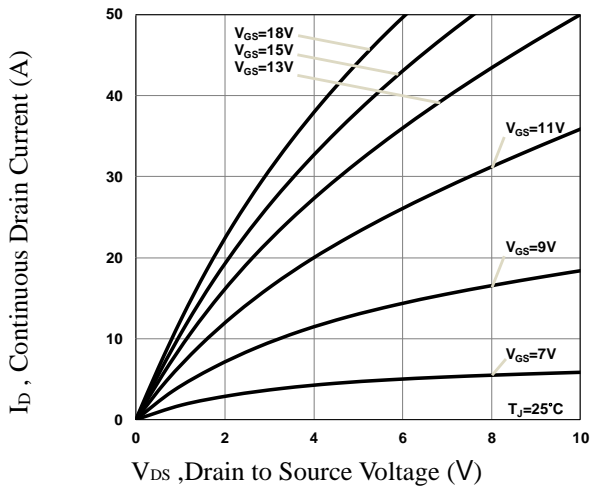

Fig.1 Typical Output Characteristics

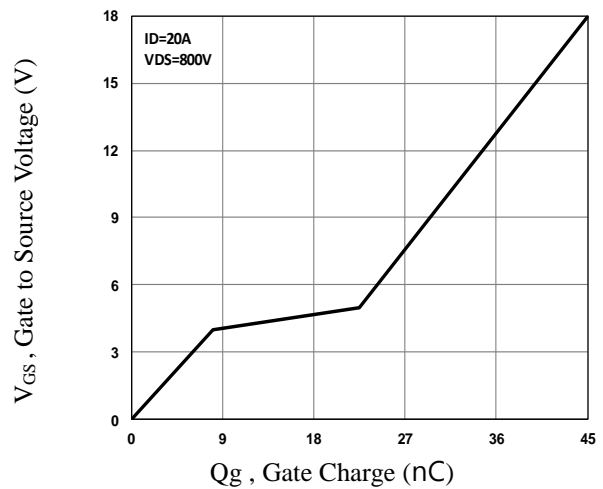

Fig.2 Gate Charge Characteristics

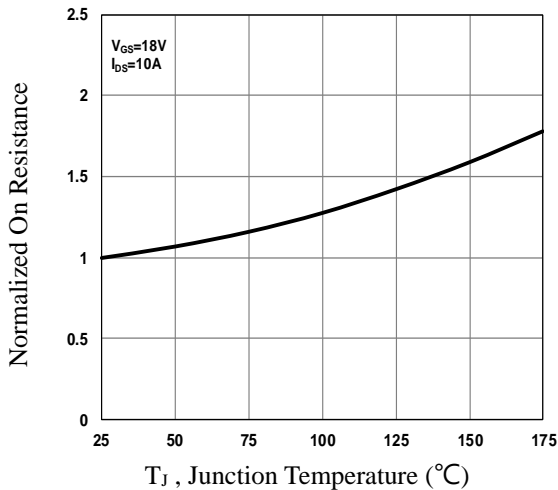

Fig.3 Normalized RDS(on) vs. Tj

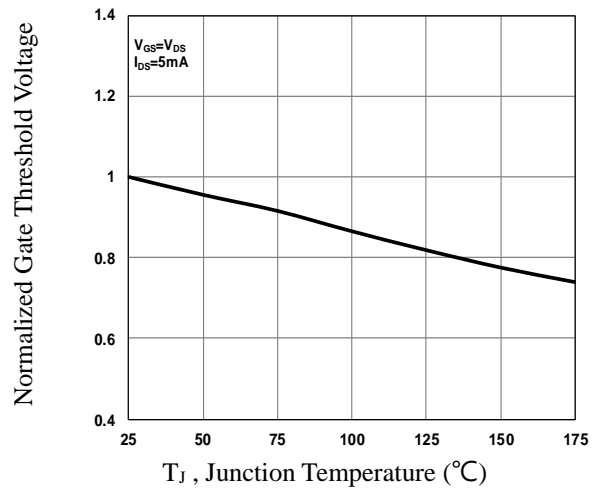

Fig.4 Normalized Vth vs. Tj

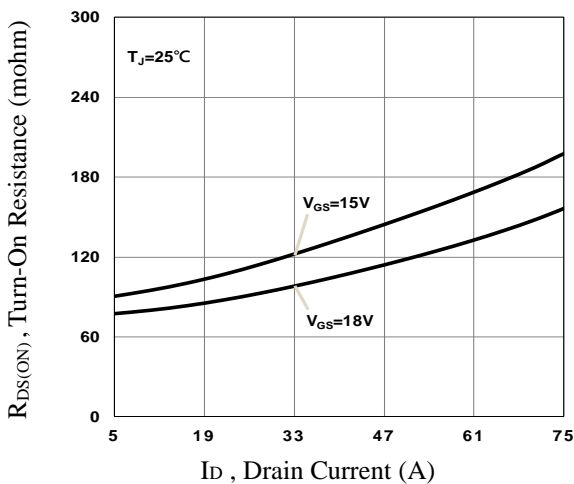

Fig.5 Turn-On Resistance vs. Id

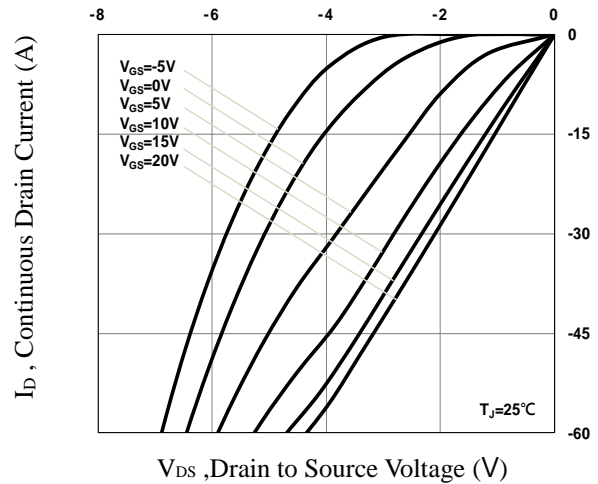

Fig.6 3rd Quadrant Characteristic

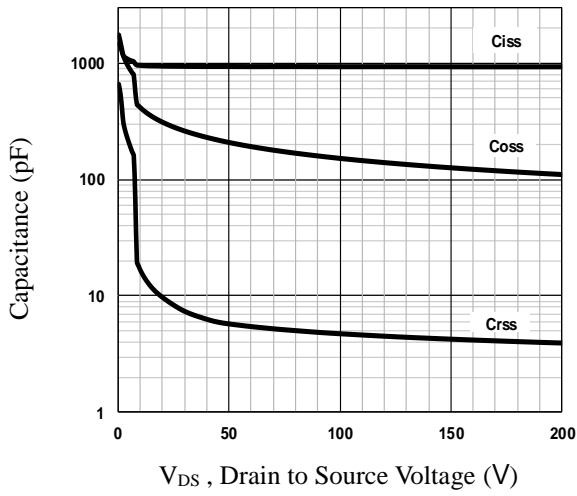

Fig.7 Capacitance Characteristics

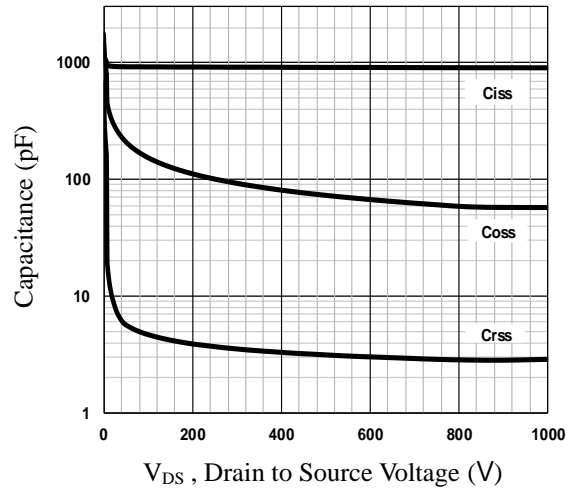

Fig.8 Capacitance Characteristics

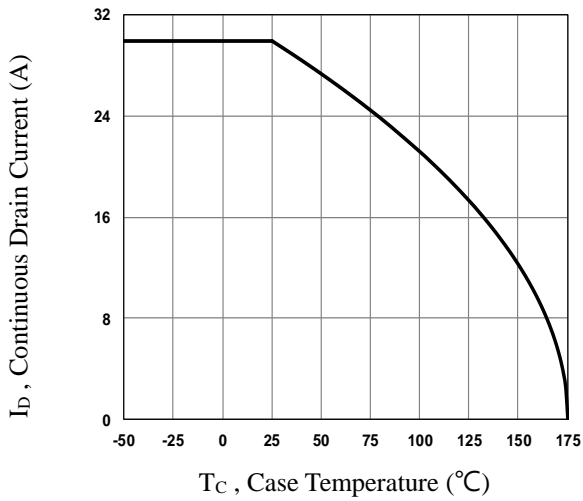

Fig.9 Continuous Drain Current vs. T_c

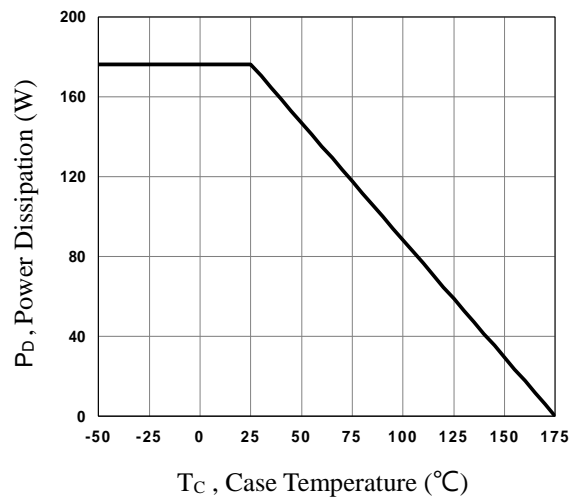
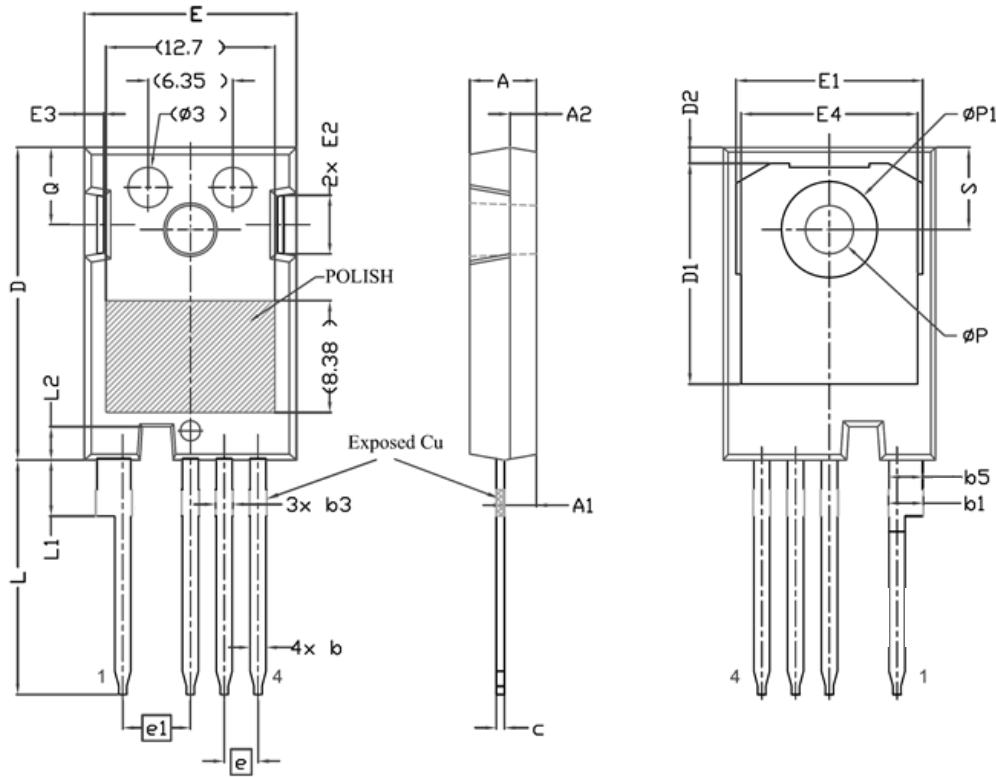

Fig.10 Power Dissipation Derating vs. T_c

TO247-4L PACKAGE INFORMATION



SYMBOL	mm		SYMBOL	mm	
	MIN	MAX		MIN	MAX
A	4.83	5.21	D2	0.95	1.25
A1	2.29	2.54	E	15.75	16.13
A2	1.91	2.16	E1	13.10	14.15
b'	1.07	1.28	E2	3.68	5.10
b	1.07	1.33	E3	1.00	1.90
b1	2.39	2.94	E4	12.38	13.43
b2	2.39	2.84	e	2.54 BSC	
b3	1.07	1.60	e1	5.08 BSC	
b4	1.07	1.50	L	17.31	17.82
b5	2.39	2.69	L1	3.97	4.37
b6	2.39	2.64	L2	2.35	2.65
c	0.55	0.68	ϕP	3.51	3.65
c1	0.55	0.65	$\phi P1$	7.19 REF.	
D	23.30	23.60	Q	5.49	6.00
D1	16.25	17.65	S	6.04	6.30