

**General Description**

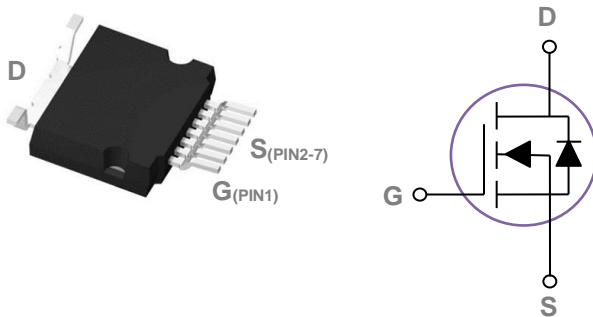
These N-Channel enhancement mode power field effect transistors are using silicon carbide technology. This advanced technology has been especially tailored to minimize on-state resistance, provide superior switching performance, and withstand high energy pulse in the avalanche and commutation mode. These devices are well suited for high efficiency fast switching applications.

BVDSS	R <sub>DS(ON)(typ)</sub>	ID
1200V	80mΩ	30A

**Features**

- 1200V,30A, R<sub>DS(ON)(typ)</sub> =80mΩ @V<sub>GS</sub> = 18V
- Improved dv/dt capability
- Fast switching
- Green Device Available

**T2PAK Pin Configuration**



**Applications**

- SMPS
- Solar Inverters
- Renewable energy
- EV battery chargers

**Absolute Maximum Ratings** T<sub>c</sub>=25°C unless otherwise noted

Symbol	Parameter	Rating	Units
V <sub>DS</sub>	Drain-Source Voltage	1200	V
V <sub>GS</sub>	Gate-Source Voltage	+22/-10	V
I <sub>D</sub>	Drain Current – Continuous (T <sub>c</sub> =25°C)	30	A
	Drain Current – Continuous (T <sub>c</sub> =100°C)	19	A
I <sub>DM</sub>	Drain Current – Pulsed <sup>1</sup>	65	A
P <sub>D</sub>	Power Dissipation (T <sub>c</sub> =25°C)	176	W
	Power Dissipation – Derate above 25°C	1.18	W/°C
T <sub>STG</sub>	Storage Temperature Range	-55 to 175	°C
T <sub>J</sub>	Operating Junction Temperature Range	-55 to 175	°C

**Thermal Characteristics**

Symbol	Parameter	Typ.	Max.	Unit
R <sub>θJC</sub>	Thermal Resistance Junction to Case	0.85	---	°C/W

**Electrical Characteristics (T<sub>J</sub>=25 °C, unless otherwise noted)**
**Off Characteristics**

Symbol	Parameter	Conditions	Min.	Typ.	Max.	Unit
BV <sub>DSS</sub>	Drain-Source Breakdown Voltage	V <sub>GS</sub> =0V , I <sub>D</sub> =100μA	1200	---	---	V
I <sub>DSS</sub>	Drain-Source Leakage Current	V <sub>DS</sub> =1200V , V <sub>GS</sub> =0V , T <sub>J</sub> =25°C	---	---	10	μA
I <sub>GSS</sub>	Gate-Source Leakage Current	V <sub>GS</sub> =22V , V <sub>DS</sub> =0V	---	---	100	nA

**On Characteristics**

R <sub>DS(ON)</sub>	Static Drain-Source On-Resistance	V <sub>GS</sub> =18V , I <sub>D</sub> =10A	---	80	104	mΩ
R <sub>DS(ON)</sub>	Static Drain-Source On-Resistance	V <sub>GS</sub> =15V , I <sub>D</sub> =10A	---	92	---	mΩ
V <sub>GS(th)</sub>	Gate Threshold Voltage	V <sub>GS</sub> =V <sub>DS</sub> , I <sub>D</sub> =5mA	2.0	2.6	4.0	V

**Dynamic and switching Characteristics**

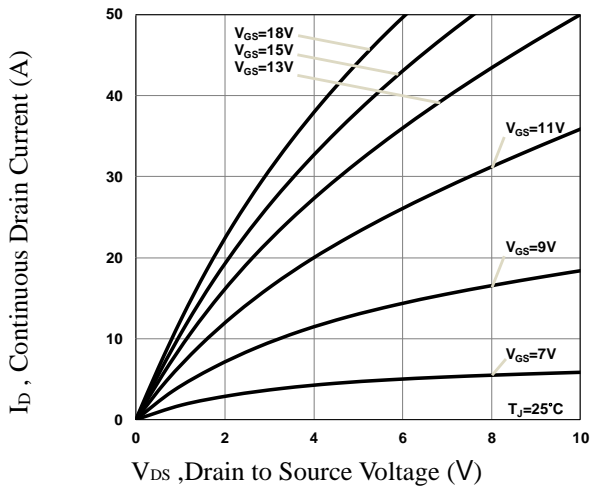
Q <sub>g</sub>	Total Gate Charge	V <sub>DS</sub> =800V , V <sub>GS</sub> =-5/18V , I <sub>DS</sub> =20A	---	45	---	nC
Q <sub>gs</sub>	Gate-Source Charge		---	8	---	
Q <sub>gd</sub>	Gate-Drain Charge		---	14.5	---	
T <sub>d(on)</sub>	Turn-On Delay Time	V <sub>DD</sub> =800V , V <sub>GS</sub> =-5/18V , R <sub>G</sub> =6Ω , I <sub>DS</sub> =20A	---	15	---	ns
T <sub>r</sub>	Rise Time		---	8	---	
T <sub>d(off)</sub>	Turn-Off Delay Time		---	16	---	
T <sub>f</sub>	Fall Time		---	8	---	
C <sub>iss</sub>	Input Capacitance	V <sub>DS</sub> =1000V , V <sub>GS</sub> =0V , F=500kHz , V <sub>AC</sub> =25mV	---	915	---	pF
C <sub>oss</sub>	Output Capacitance		---	57	---	
C <sub>rss</sub>	Reverse Transfer Capacitance		---	3	---	
R <sub>g</sub>	Gate resistance	V <sub>GS</sub> =0V , V <sub>DS</sub> =0V , F=1MHz	---	1	---	Ω

**Drain-Source Diode Characteristics and Maximum Ratings**

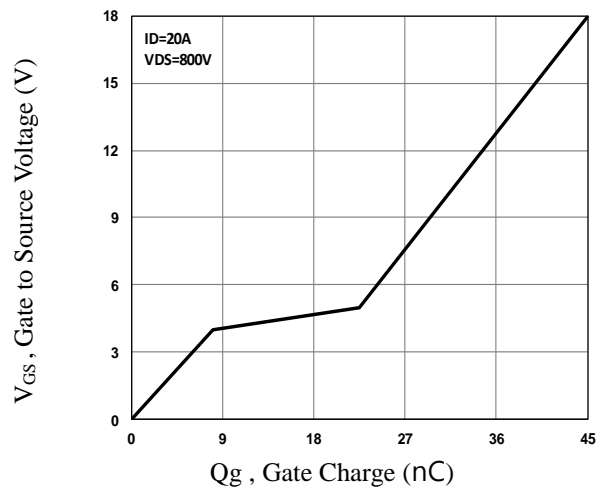
Symbol	Parameter	Conditions	Min.	Typ.	Max.	Unit
I <sub>S</sub>	Continuous Source Current	V <sub>G</sub> =V <sub>D</sub> =0V , Force Current	---	---	30	A
V <sub>SD</sub>	Diode Forward Voltage	V <sub>GS</sub> =-5V , I <sub>S</sub> =10A , T <sub>J</sub> =25°C	---	4.4	---	V
t <sub>rr</sub>	Reverse Recovery Time	V <sub>R</sub> =400V , I <sub>S</sub> =20A	---	42	---	ns
Q <sub>rr</sub>	Reverse Recovery Charge	di/dt=300A/μs , T <sub>J</sub> =25°C	---	65	---	nC

Note :

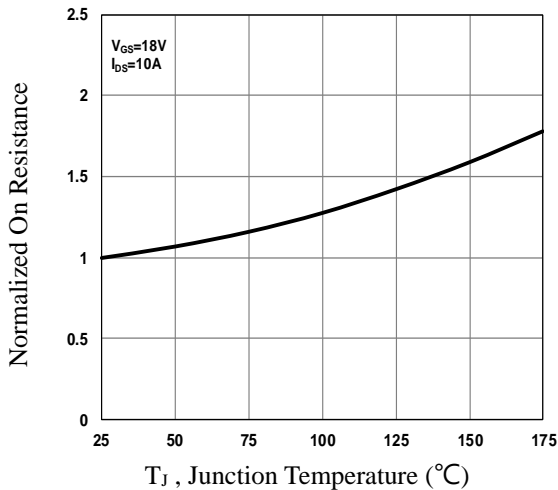
1. Repetitive Rating : Pulsed width limited by maximum junction temperature.
2. The data tested by pulsed , pulse width ≤ 300μs , duty cycle ≤ 2%.



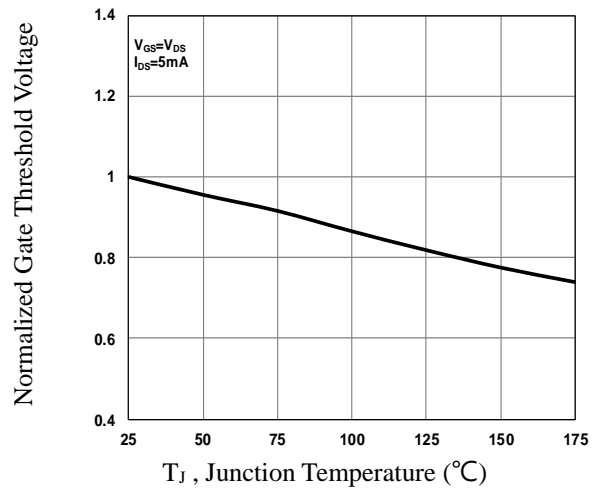
**Fig.1 Typical Output Characteristics**



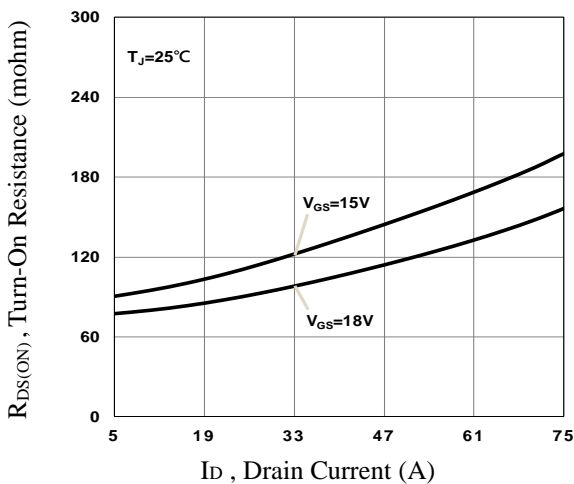
**Fig.2 Gate Charge Characteristics**



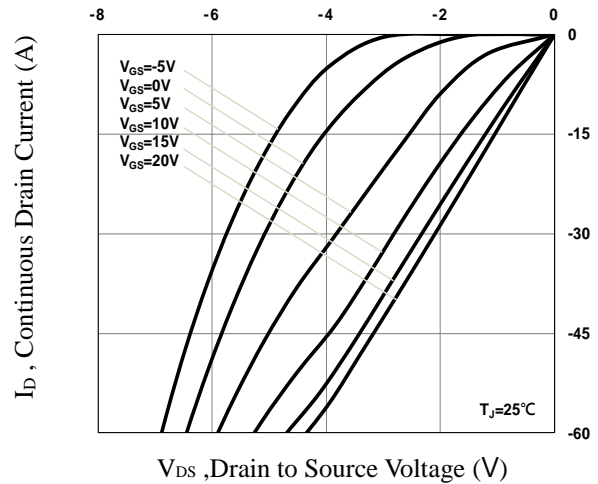
**Fig.3 Normalized RDS(on) vs. Tj**



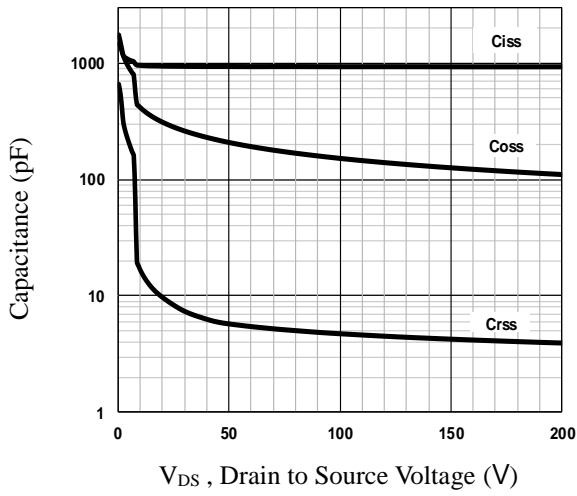
**Fig.4 Normalized Vth vs. Tj**



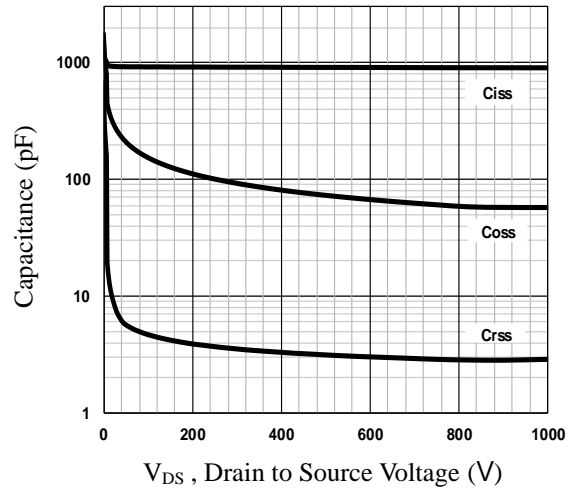
**Fig.5 Turn-On Resistance vs. Id**



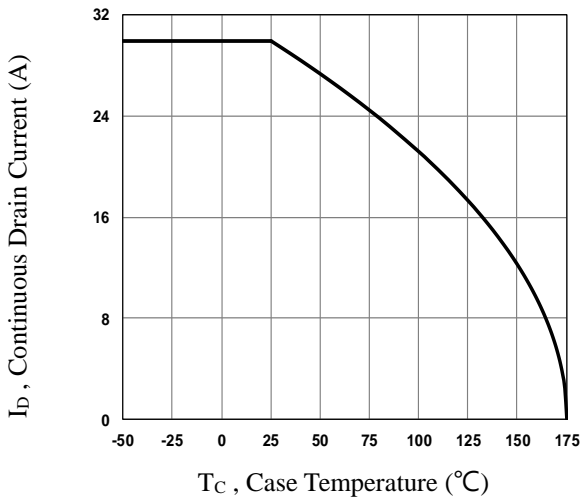
**Fig.6 3rd Quadrant Characteristic**



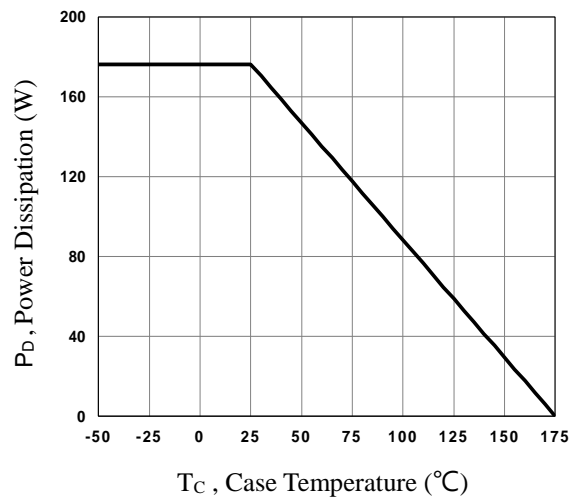
**Fig.7 Capacitance Characteristics**



**Fig.8 Capacitance Characteristics**

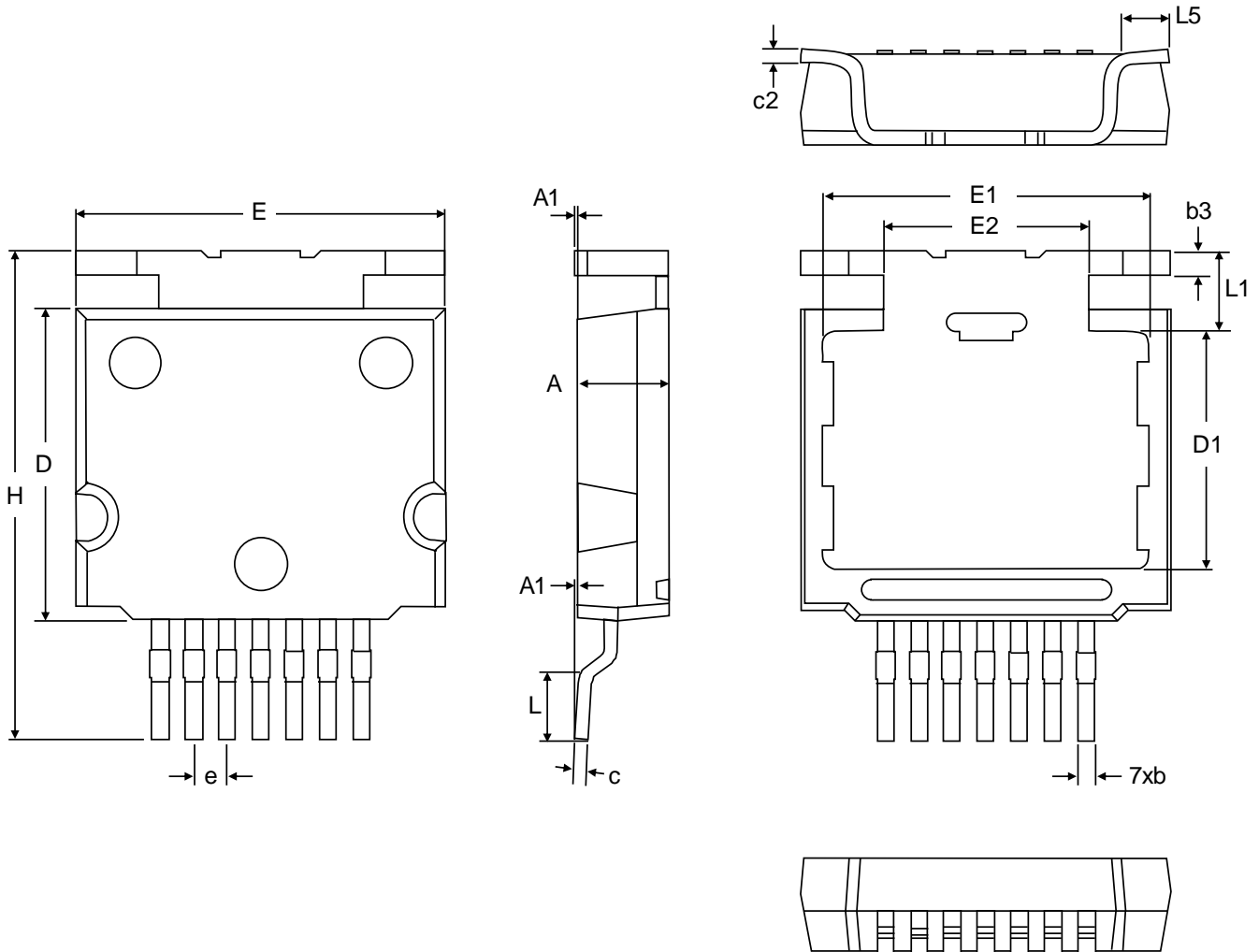


**Fig.9 Continuous Drain Current vs.  $T_c$**



**Fig.10 Power Dissipation Derating vs.  $T_c$**

## T2PAK PACKAGE INFORMATION



Symbol	Dimensions In Millimeters		Symbol	Dimensions In Millimeters	
	MIN	MAX		MIN	MAX
A	3.40	3.60	E	13.90	14.10
A1	0.00	0.25	E1	12.30	12.50
b	0.50	0.70	E2	7.75	7.85
b3	0.80	1.00	e	1.27BSC	
c	0.40	0.60	H	18.00	19.00
c2	0.40	0.60	L	2.30	2.75
D	11.70	12.00	L1	3.05NOM	
D1	8.80	9.10	L5	1.70	2.15

### T2PAK RECOMMENDED LAND PATTERN

