

General Description

These 1200V high performance series of SiC schottky diodes are using the most advanced technology to suit for high frequency and high efficiency power systems with extreme low reverse recovery charge and can be stand up to 175°C maximum junction temperature.

V_{BR}	$I_F (T_C = 155^\circ\text{C})$	Q_C
1200V	5A	19nC

TO220-2L Pin Configuration

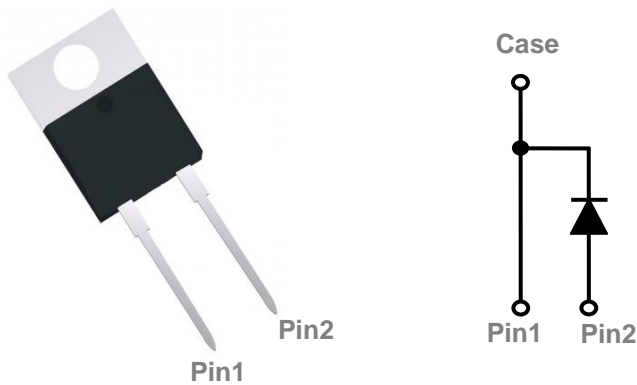

Features

- 1200V , 5A , 175°C junction temperature
- Extremely fast switching
- Ultra Low Reverse Recovery Current
- Positive temperature coefficient
- Green device available

Applications

- Switching mode power supplies
- Motor drives
- Power Converters
- PFC, Power factor correction

Absolute Maximum Ratings ($T_C=25^\circ\text{C}$ unless otherwise noted)

Symbol	Parameter	Rating	Units
V_R	DC Peak Reverse Voltage, $T_J=25^\circ\text{C}$	1200	V
V_{RRM}	Repetitive Peak Reverse Voltage, $T_J=25^\circ\text{C}$	1200	V
V_{RSM}	Surge Peak Reverse Voltage, $T_J=25^\circ\text{C}$	1300	V
I_F	Continuous Forward Current, $T_C=25^\circ\text{C}$	15	A
	Continuous Forward Current, $T_C=155^\circ\text{C}$	5	A
I_{FSM}	Non-Repetitive Forward Surge current $T_C = 25^\circ\text{C}$, $T_P=10\text{ms}$ Half Sine Pulse	54	A
T_J	Maximum operating Junction Temperature Range	175	$^\circ\text{C}$
T_{STG}	Storage Temperature Range	-55 to 175	$^\circ\text{C}$

Thermal Characteristics

Symbol	Parameter	Typ.	Max.	Unit
$R_{\theta JC}$	Thermal Resistance Junction to Case	---	1.6	$^\circ\text{C}/\text{W}$

Electrical Characteristics ($T_J=25\text{ }^\circ\text{C}$, unless otherwise noted)

Symbol	Parameter	Conditions	Min.	Typ.	Max.	Unit
VDC	DC Blocking Voltage	$I_R=100\mu\text{A}$, $T_J=25^\circ\text{C}$	1200			V
V _F	Forward Voltage	$I_F=5\text{A}$, $T_J=25^\circ\text{C}$	---	1.6	1.8	V
		$I_F=5\text{A}$, $T_J=155^\circ\text{C}$	---	2.4	2.7	V
I _R	Reverse Current	$V_R=1200\text{V}$, $T_J=25^\circ\text{C}$	---	---	100	uA
		$V_R=1200\text{V}$, $T_J=175^\circ\text{C}$	---	---	500	uA
Q _C	Total Capacitive Charge	$V_R=800\text{V}$, $I_F=5\text{A}$ $di/dt=300\text{A/us}$, $T_J=25^\circ\text{C}$	---	19	---	nC
C	Total Capacitance	$V_R=10\text{V}$, $f=1\text{MHz}$	---	125	---	pF
		$V_R=600\text{V}$, $f=1\text{MHz}$	---	27	---	
		$V_R=900\text{V}$, $f=1\text{MHz}$	---	25	---	

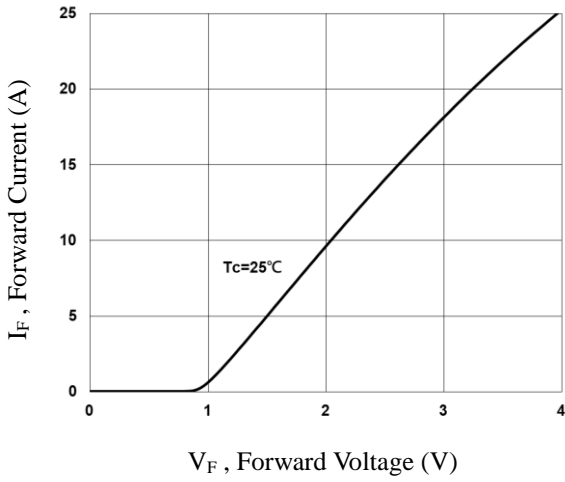

Fig.1 Forward Characteristics

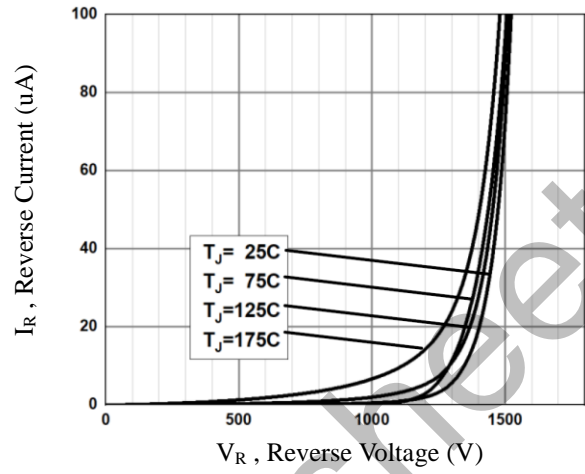

Fig.2 Reverse Characteristics

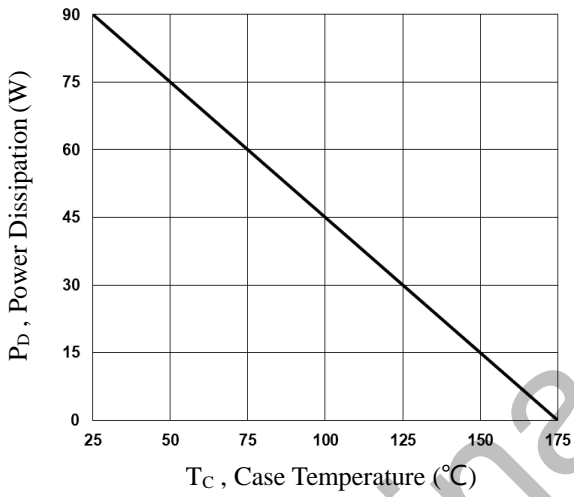

Fig.3 Power Dissipation

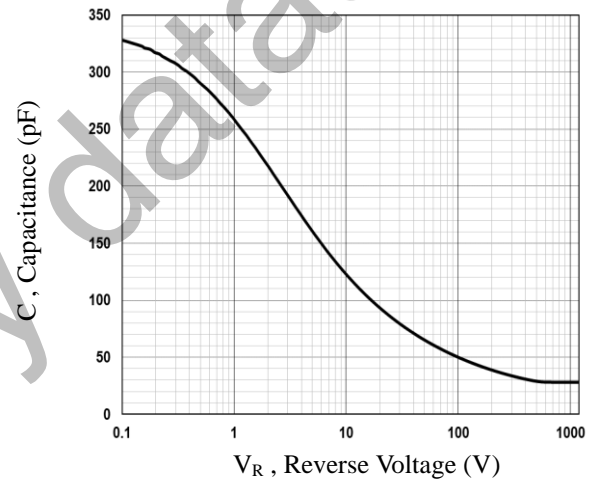
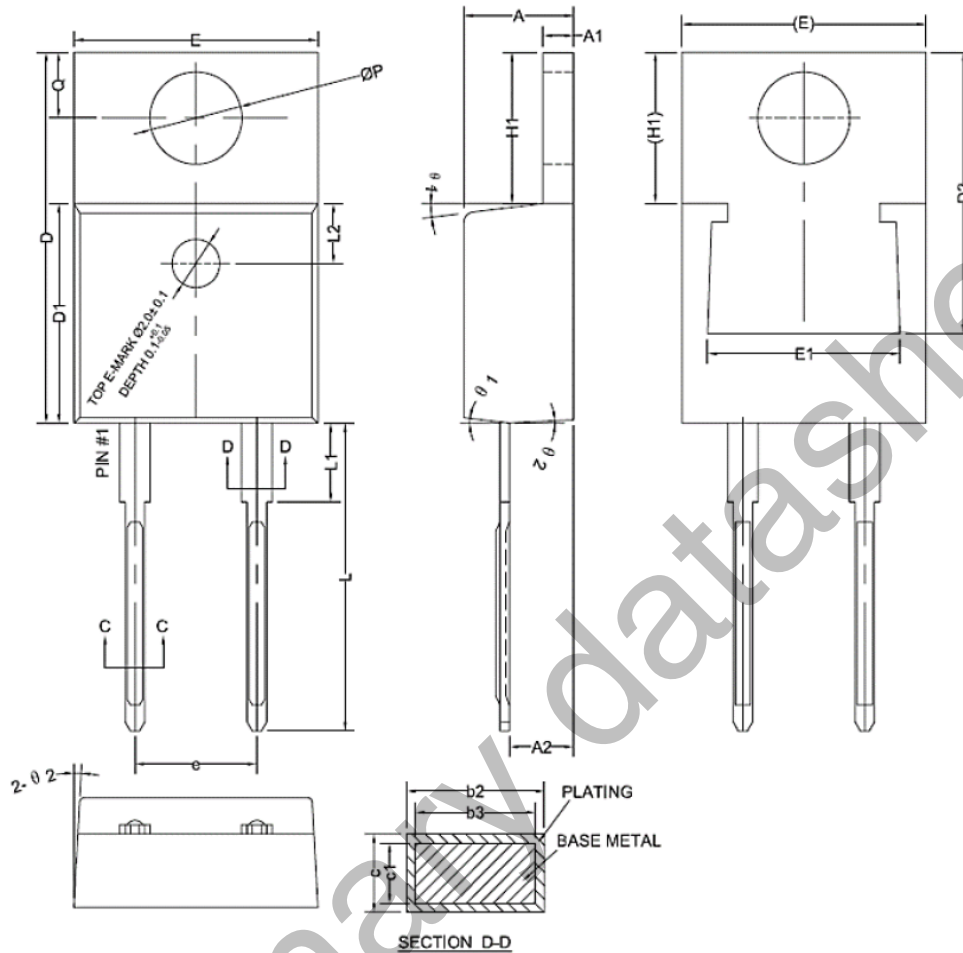

Fig.4 Capacitance Characteristics

TO220-2L PACKAGE INFORMATION



SYMBOL	mm			SYMBOL	mm		
	MIN	NOM	MAX		MIN	NOM	MAX
A	4.35	4.55	4.75	E	9.85	10.10	10.30
A1	1.25	---	1.35	E1	7.60	---	8.20
A2	2.2	2.6	2.8	e	4.90	5.10	5.20
b2	1.15	1.32	1.45	H1	6.35	6.45	6.55
b3	1.12	---	1.42	L	12.70	---	13.20
c	0.45	0.55	0.60	L1	2.80	---	3.40
c1	0.42	---	0.57	ØP	3.30	3.60	3.85
D	15.15	15.50	16.00	Q	2.80	---	2.95
D1	9.05	9.15	9.25	θ1	5°	7°	9°
D2	12.20	---	14.00	θ1	1°	3°	5°